

LF690 - Ceramic Seated Technology



Water glycol applications for 20,000psi/1380 bar

The LF-690 uses Ceramic Seating to provide ultimate protection against the harsh service encountered on hydraulic services. The unique seating cartridge provides a dampening action on this critical component to prevent 'chattering' or 'unstable frequency resonance'. The regulator is self relieving with segregated captured vent to prevent deterioration to the loading mechanism and making the regulator cleaner to service. Pressure Tech's LF-690 allows flow rates up to 15lpm and stable pressure control across the range.

● PRECISION CONTROL

In high pressure systems, the fit between the valve and seat is critically important to the effectiveness of the seal and the efficiency of the system. Poor fits caused by uneven wear or unstable resonance cause leakages across the seal, which means more frequent maintenance and increased downtime.

Pressure Tech's innovative Shuttle Ball option for the proven LF-690 regulator maintains a perfect seal by wearing evenly and avoiding unstable frequency resonance.

● LASTS 5 TIMES LONGER

Uniquely, the Shuttle Ball is made out of a new, extremely hard, chemically resistant TX2000 ceramic material. It resists cavitation and erosion and in independent extreme testing, using sand and water at high pressure, lasted many times longer than tungsten carbide. This much longer life delivers greater efficiency and lower costs for your business.

● REDUCING DOWNTIME

The combination of highly effective design and extremely hardwearing materials reduces down-time, enables greater precision control and offers a considerably longer service life. What's more, as with all Pressure Tech's LF690 series, the Shuttle Ball can easily be accessed from the base of the regulator, for speedy servicing in situ.

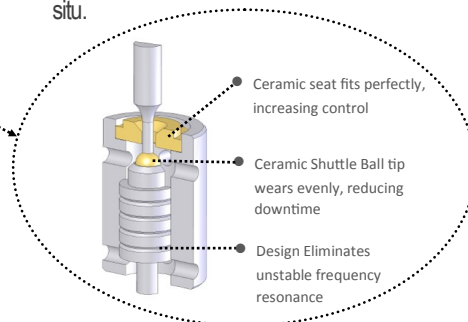

WHERE FAILURE IS NOT
AN OPTION



PRESSURE TECH LTD, Unit 24, Graphite Way, Hadfield, Glossop,
Derbyshire SK13 1QH
Tel: +44 (0) 1457 899307 Fax: +44 (0) 1457 899308
E-mail: info@pressure-tech.com

www.pressure-tech.com

Designed and built in the UK

